



**CELETTE®**



# PLASMA CUT 40NH

ORIGINAL MANUAL

PRODUCT REF NO: CEL.1721-B2-03

01/2023 - REV. 1.0

# TABLE OF CONTENTS

FOREWORD.....	Page 3
1 DESCRIPTION OF TECHNICAL SPECIFICATIONS.....	Page 4
2 DESCRIPTION OF UNIT DEVICES.....	Page 5
3 SETTING AT WORK.....	Page 6
4 CUTTING TROUBLE.....	Page 7
5 PRACTICAL RECOMMENDATIONS.....	Page 7
6 TORCH MAINTENANCE.....	Page 8
7 MAINTENANCE AND CONTROL.....	Page 8
8 WIRE DRAWING.....	Page 15
9 PLASMA CUT40NH 1PH/230V EUROPE/INDIA.....	Page 16
10 PLASMA CUT40NH 1PH/220V USA.....	Page 17

## FOREWORD:



### **READ THIS MANUAL CAREFULLY BEFORE USING THE MACHINE.**

Failure to respect the rules described herein shall exempt the manufacturer from any liability. The machine has been designed, built and protected for the functions described below. Any other use not explicitly included shall be considered FORBIDDEN.

The machine must be used in sufficiently ventilated rooms, in the absence of dust and moisture; in any case, where there is no risk of fire, explosion, or flooding.

The machine must be started, used and serviced by qualified personnel. Always follow current safety regulations.

The manufacturer shall not be held responsible for any damage caused by incorrect use of the machine.

### **INTRODUCTION:**

THIS DEVICE must be used exclusively for cutting on any electrically conductive material (metals and alloys). PLASMA cutting takes place due to the high temperature generated by a concentrated electric arc, and thus highly dangerous situations may arise; it is therefore essential to pay the utmost attention to the chapter entitled SAFETY PRECAUTIONS.

This manual must be kept carefully in a place familiar to everyone involved in using the machine. It must be consulted whenever doubts arise and be kept for the entire life-span of the machine; it will also be used for ordering replacement parts.

### **NOTE:**

1. Only use original spares.
2. Always replace any damaged part of the unit or torch with original material.
3. Do not use any torches other than the original one.
4. Do not let the unit work without covers. This would be dangerous for operator and for those who are surrounding the work area and would prevent the unit from cooling efficiently.

# 1. DESCRIPTION OF TECHNICAL SPECIFICATIONS:

**NOTE:**

Should there be a claim for losses or damages it must be made by the purchaser directly to the shipper who handled the goods.

When requesting information about this welding machine please state the machine's part number and serial number to ensure receiving accurate information relating to your machine.

The content are just for your reference.

Please be subject to the actual products if anything different or updated.

**MODEL:** The model of the machine

**ENXXX:** International Standards

**SN:** Machine Serial Number which must appear on requests or inquiries concerning the machine

 Single-phase transformer-rectifier

**1-50/50Hz:** Single-phase input supply at 50 or 60 Hz

**Uo:** Secondary no-load voltage (peak value)

**X:** Duty-Cycle Percentage

The duty-cycle is the number of minutes, expressed as a percentage, the machine can operate (arc on) within a ten minute period without overheating. The duty cycle varies according to the output current.



**I2:** Output welding current

**I1:** Input Amps absorbed corresponding to different output levels (I2)

**U2:** Secondary voltage with welding current I2

**U1:** Nominal supply voltage

**IP21:** Machine case protection class. The 1 in the second digit place means that this unit is not fit to work outdoors in the rain.

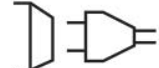
MODEL		SN		
		ENXXXX		
		-A/-V---A/-V		
		X	-%	-%
	U0 =	I2	-A	-A
		U2	-V	-V
 1~50/60Hz	U1 =	I1	-A	-A
		S1	-V	-V
IP21				



### 3. SETTING AT WORK:

**The unit must be installed by skilled personnel. All fillings must be in conformity with the existing rules and in full compliance with safety regulations.**

Connect the air making sure that pressure is 0.3 Mpa at least .Normal 0.3-0.5Mpa.Adjust the pressure according to the workpiece. Recommended value is 0.4Mpa.

Should air feed come from a pressure reducing unit of a compressor or of a centralized plant, the reducing unit should be adjusted at the highest output pressure which should not exceed 0.8 MPa. Should air feed come from a compressed air bottle, this should be provided with a pressure regulator: never connect compressed air bottles directly to the reducing unit! Pressure may exceed the reducing unit capacity and then explode!

Check that the mains power supply matches that indicated on the front panel of the machine.

Connect supply cable A: the yellow-green wire of cable must be connected to an efficient earth plug of the system, the remaining wires should be connected to the feed line by means of the switch placed, if possible, close to the cutting area so as to switch the unit off quickly if necessary.

#### **USE:**

Turn on the mains switch D.

By pressing for a second the torch button, the compressed air flow is opened.

Connect work clamp H to the piece to be cut.

Every machine has been disposed a power cable which must be connected to coordinated voltage class in compliance according to input voltage of cutting machine .If cutting machine whose power voltage is 200v is connected wrong to AC 380v ,that will cause components of inter-machine are burned up.

Make sure power cable A is connected to power switch reliably and prevent from oxidizing.

Make sure power voltage is inside the waved range.

Welding circuit should not be deliberately placed in direct or indirect contact with protection wire if not in the workpiece. If earthing is deliberately made on the workpiece by means of protection wire, the connection must be as direct as possible, with the wire having a section at least equal to the welding return current wire and connected to the piece being worked on, in the same place as the return wire, using the return wire terminal or a second earth terminal closeby.

All possible precautions must be taken in order to avoid stray currents.

Clean the work piece to ensure good electrical contact of the work clamp.

Do not connect work clamp to the material to be removed.

Press torch button to start pilot arc, if cutting does not start after 2 or 3 seconds, the pilot arc turns off and the button should be pressed again to repeat the operation.

When possible, the torch should be pulled. Pulling is easier than pushing.

Keep torch in vertical position when cutting.

Once cutting is over and after releasing button, air continues to flow out of the torch for about 40 seconds so it enables torch to cool down. It is recommended not to turn the unit off before that time. Should holes be drilled or should the piece be cut starting from its center, torch should be tilted and then slowly straighten to prevent molten metal from being spread on nozzle (see picture 4). This operation should be carried out with material thickness above 2 mm. If you have to cut near angles or recesses (see picture 5) it is recommended to use extended electrodes and nozzles.

**NB: Avoid keeping pilot arc uselessly on, in air to avoid electrode, and nozzle consumption.**



**READ THIS MANUAL CAREFULLY BEFORE USING THE MACHINE.**

## 4. CUTTING TROUBLE:

### 1. Insufficient penetration

This may be due to:

High speed. Always make sure that arc thoroughly passes through the piece to be cut and that it is not tilted, when going forward, by a percentage above 10 / 15°(see picture 6). It is thus avoided to wear nozzle (see picture 7) out and to burn the nozzle holder (see picture 8). Excessive thickness of piece (see graph of cutting speed and thickness), Work clamp H not properly in electric contact with piece, Worn nozzle and electrode, Too low cutting current.

**NB: When the unit does not thoroughly pass through, nozzle is clogged by scums.**

### 2. Cutting arc switches off

This may be due to:

Worn nozzle, electrode or diffuser B, too high air pressure, too low feed voltage.

### 3. Tilted cutting

When cutting is tilted (see picture 9) switch the unit off, loosen nozzle holder and turn nozzle by a quarter turn, then lock and try again. Repeat until cutting is straight (see picture 10).

### 4. Excessive wear of consumable parts

This may be due to:

- A. Too low air pressure with respect to the recommended one.
- B. Excessive burns on the end part of nozzle holder.

## 5. PRACTICAL RECOMMENDATIONS:

If the system air contains much humidity and oil it is required to use a drying filter to avoid excessive oxidation and wear of consumable parts, to avoid torch damage or to reduce speed and quality of cutting. Impurities of air favour oxidation of electrode and nozzle and make it difficult to start pilot arc. If this occurs, clean the end part of electrode and inside the nozzle with fine abrasive paper.

Make sure that new electrode and nozzle to fit are clean and degreased.

**To avoid damage of torch and to prevent dangerous situations always use genuine spares.**

## 6. TORCH MAINTENANCE:

The introduction for torch are just for your reference.

Please be subject to the actual products if anything different or updated.

Replace wear parts (picture 11).

The parts subject to wear are electrode A, diffuser B and nozzle C. nozzle holder D.

Either part may be only replaced after loosening nozzle holder D. Electrode A should be replaced when a 1.5mm deep crater is created in the middle (see picture 12).

**ATTENTION! Do not make sudden stresses when unscrewing the electrode, but gradually force so as to have the thread unlocked. Lubricate the thread of the new electrode with silicone lubricant (on supply with the unit). This new electrode is required to be screwed in its housing and locked without tightening.**

Nozzle C should be replaced when its central hole is damaged or enlarged with respect to the new part (see picture 13).

Use of worn electrode quickly wears out the nozzle.

Excessive use of electrode causes overheating and reduces the life of diffuser B.

Make sure that after replacing it, nozzle D is tight enough.

**ATTENTION! Nozzle holder D should be only screwed on head when electrode A diffuser B and nozzle C are assembled.**

**The absence of such parts jeopardizes the machine working and particularly the operator's safety.**

## 7. MAINTENANCE AND CONTROL:

It is recommended to keep nozzle free from slag.

Avoid using sharpened bodies thus avoiding damaging the nozzle hole.

Even if the unit is provided with an automatic device for water discharge, working whenever air feed is closed, it is recommended to check from time to time that no water remains in trap I of reducer (picture 1).

It is required to clean from time to time the unit inside and make it free from metal dust by means of compressed air.

Operations to be carried out inside the unit must be effected after disconnecting feed cable.

### **BASIC SAFETY PRECAUTIONS:**

#### **ELECTRIC SHOCK:**

- ▶▶ Electric shock can kill. All electric shocks are potentially fatal. This plasma cutter requires high voltages for arc spark starting (approx. 250 / 350 V). The following safety rules must be therefore observed when using the unit:
- ▶▶ Do not touch live parts.
- ▶▶ Insulate yourselves from the piece to be cut and from earth by wearing insulating gloves and clothing.
- ▶▶ Keep your clothing (gloves, shoes, hats, dresses) and body dry.
- ▶▶ Do not work in humid or wet areas.
- ▶▶ Avoid touching or holding by hand the piece to be cut.
- ▶▶ Always arrange for a proper insulation against electric shock.
- ▶▶ Should you work close to or in a dangerous area use all possible precautions.
- ▶▶ If you feel even the slightest electric shock sensation, stop cutting at once. Do not use the machine until the problem is identified and solved.



- ▶▶ Always fit an automatic wall switch with adequate power. if possible close to the machine so as to immediately switch the unit off in an emergency event.
- ▶▶ Check often mains cable, torch cable, earth cable and torch.
- ▶▶ Never use the unit when one of them is damaged. Replace them immediately.
- ▶▶ Disconnect mains cable from mains before replacing cables or before removing unit covers.
- ▶▶ Always switch the unit off or disconnect it before replacing nozzle, swirl ring, electrode or nozzle holder.
- ▶▶ Do not use the unit without protecting covers.
- ▶▶ Always replace any damaged parts of the unit, torch and cables with original material. Never remove torch or unit safety devices.
- ▶▶ Make sure that the supply mains line is equipped with an efficient earth plug.
- ▶▶ Make sure that the work table is connected to an efficient earth plug.
- ▶▶ Maintenance should be only carried out by qualified personnel aware of the risks due to dangerous voltages necessary to make the unit work.

### **RADIATIONS:**

- ▶▶ Ultraviolet radiations created by the arc may damage your eyes and burn your skin.
- ▶▶ Wear proper clothing and helmets.
- ▶▶ Do not use contact lenses! The intense heat coming from the arc may stick them on the cornea.
- ▶▶ Use masks with grade DIN 10 safety lenses, at least.
- ▶▶ Protect people surrounding the cuffing area.

### **FUMES:**

- ▶▶ Cutting operations give off fumes and harmful metal dusts which may damage health, therefore:
- ▶▶ Do not work in areas without proper ventilation.
- ▶▶ Keep your head out of fumes.
- ▶▶ In closed rooms use suitable exhaust fans, placed under the cutting area, if possible.
- ▶▶ If ventilation is not enough, use breathing sets approved for this procedure.
- ▶▶ Clean the material to be cut of any solvents or halogen degreasers giving rise to toxic gases when cutting: Some chlorine solvents may decompose with radiation emitted by the arc and create phosgene gas.
- ▶▶ Do not cut plated metals or metals containing lead, graphite, cadmium, zinc, chrome, quicksilver or beryllium unless you have a proper breathing set.
- ▶▶ The electric arc creates ozone. After long exposure to high concentrations of ozone you may have headache, nose, throat and eyes irritation as well as serious congestion and chest pains.

### **IMPORTANT: DO NOT USE OXYGEN FOR VENTILATION.**

### **FIRE:**

- ▶▶ Avoid causing fire because of sparks, hot metal or pieces.
- ▶▶ Make sure that suitable fireproof devices are available close to cutting area.
- ▶▶ Remove from cutting area and surrounding area (33 feet at least) all inflammable and combustible material.
- ▶▶ Do not cut containers of combustible or lubricating material, even when empty. These should be carefully cleaned before being cut.

- ▶▶ Let the material cut cool down before touching it or putting it in contact with combustible or inflammable material.
- ▶▶ Do not cut parts with hollow spaces including inflammable material.
- ▶▶ Do not work under conditions of high concentration of combustible vapours, gases or inflammable dust.
- ▶▶ Always check the work area half an hour after cutting so as to make sure that no fire is starting to burn.

#### **BURNS:**

- ▶▶ Wear fire-proof clothes all over your body to protect your skin against burns caused by ultraviolet radiations from the arc, from sparks and hot metal.
- ▶▶ Wear no turn-up trousers to prevent sparks and metal to deposit in them.
- ▶▶ Wait for the torch to be cooled down and then switch the unit off before touching the front side of the torch.
- ▶▶ Torch is provided with a pilot arc, then as soon as you press the button, the plasma spark starts even if earth cable is not connected. Avoid directing jet towards your own body or towards other people surrounding the cutting area.
- ▶▶ To prevent spark to starts by chance, always switch the unit off before putting down your torch.
- ▶▶ Do not carry combustible material, such as lighters or matches in pocket.

#### **EXPLOSIONS:**

- ▶▶ Do not cut above or near containers under pressure.
- ▶▶ Do not cut in environments containing explosive 4 dusts, gases or vapours.
- ▶▶ This plasma cutter uses compressed air to work; should you use compressed air bottles follow suitable precautions:

#### **A. CYLINDERS:**

- ▶▶ Do not directly connect cylinders to reducing unit without a pressure regulator; pressure might exceed the reducing unit capacity making it explode.
- ▶▶ Feeding pressure must not exceed 0.8MPa.
- ▶▶ Handle or use pressure cylinders in conformity with the existing rules.
- ▶▶ Do not use leaking or damaged cylinders.
- ▶▶ Do not use cylinders which are not properly secured.
- ▶▶ Do not carry cylinders whose content is not clearly identified.
- ▶▶ Never lubricate cylinder valves with oil or grease.
- ▶▶ Do not put electrically in contact cylinder with plasma arc.
- ▶▶ Do not expose cylinders to excessive heat, sparks, hot metal or flames.
- ▶▶ Do not tamper with cylinder valves.
- ▶▶ Do not try to loosen all tight valves by means of hammers, keys or something else.

#### **B. PRESSURE REGULATORS:**

- ▶▶ Keep pressure regulators in good conditions. Damaged regulators may give rise to damage or accidents; they should only be repaired by skilled personnel.
- ▶▶ Do not use regulators for gases other than those they are manufactured for.
- ▶▶ Never use a leaking or damaged regulator.
- ▶▶ Never lubricate regulators with oil or grease.

#### **C. AIR HOSES:**

- ▶▶ Replace air hoses if damaged.
- ▶▶ Keep hoses unwound so as to avoid bending.
- ▶▶ Keep excess hose wound and keep it out of the working area to avoid any damage.

**NOISE:**

- ▶▶ These power sources alone do not produce noise levels exceeding 80 dB. The cutting procedure, however, may produce noise levels in excess of 80 dB in which case the operator must take the necessary safety precautions as prescribed by the national safety regulations.

**PACEMAKER:**

Magnetic fields created by the high currents in the cutting circuit can affect pacemaker operation. Persons wearing electronic life support equipment (pacemakers) should consult their doctor before going near any arc welding, gouging, cutting,, or spot welding equipment in operation.

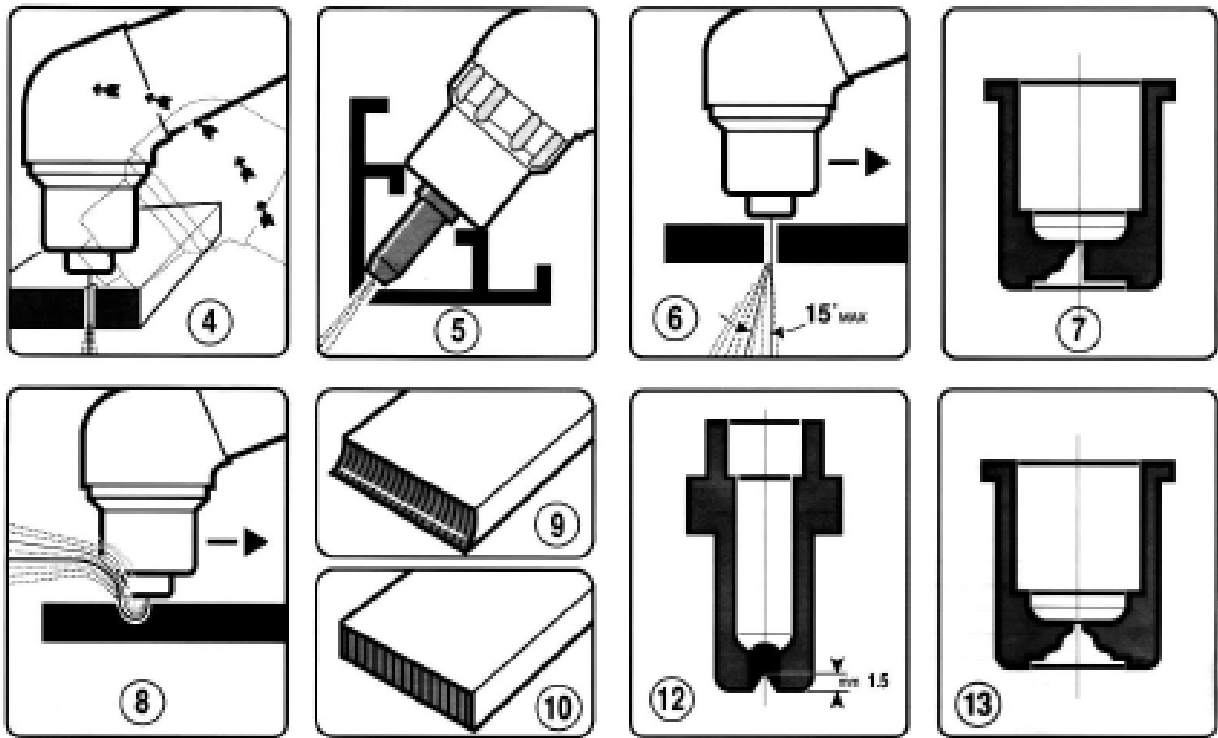

PICTURE 4-13

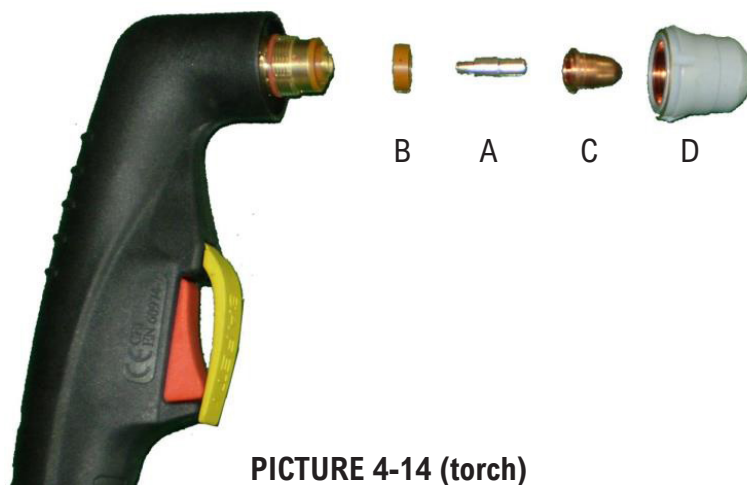

PICTURE 4-14 (torch)

## CUT40 NO HF TROUBLE SHOOTING

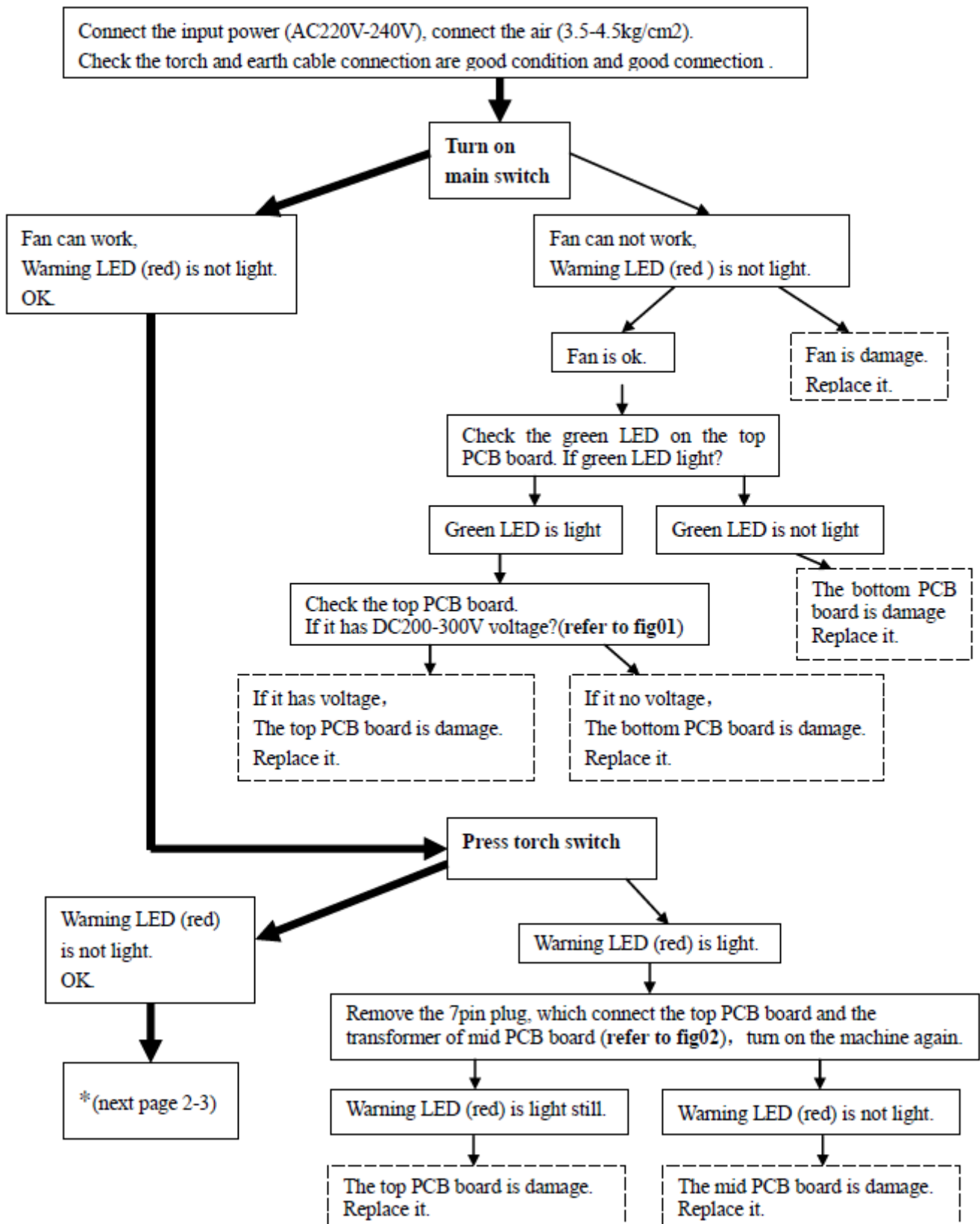
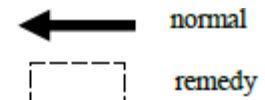

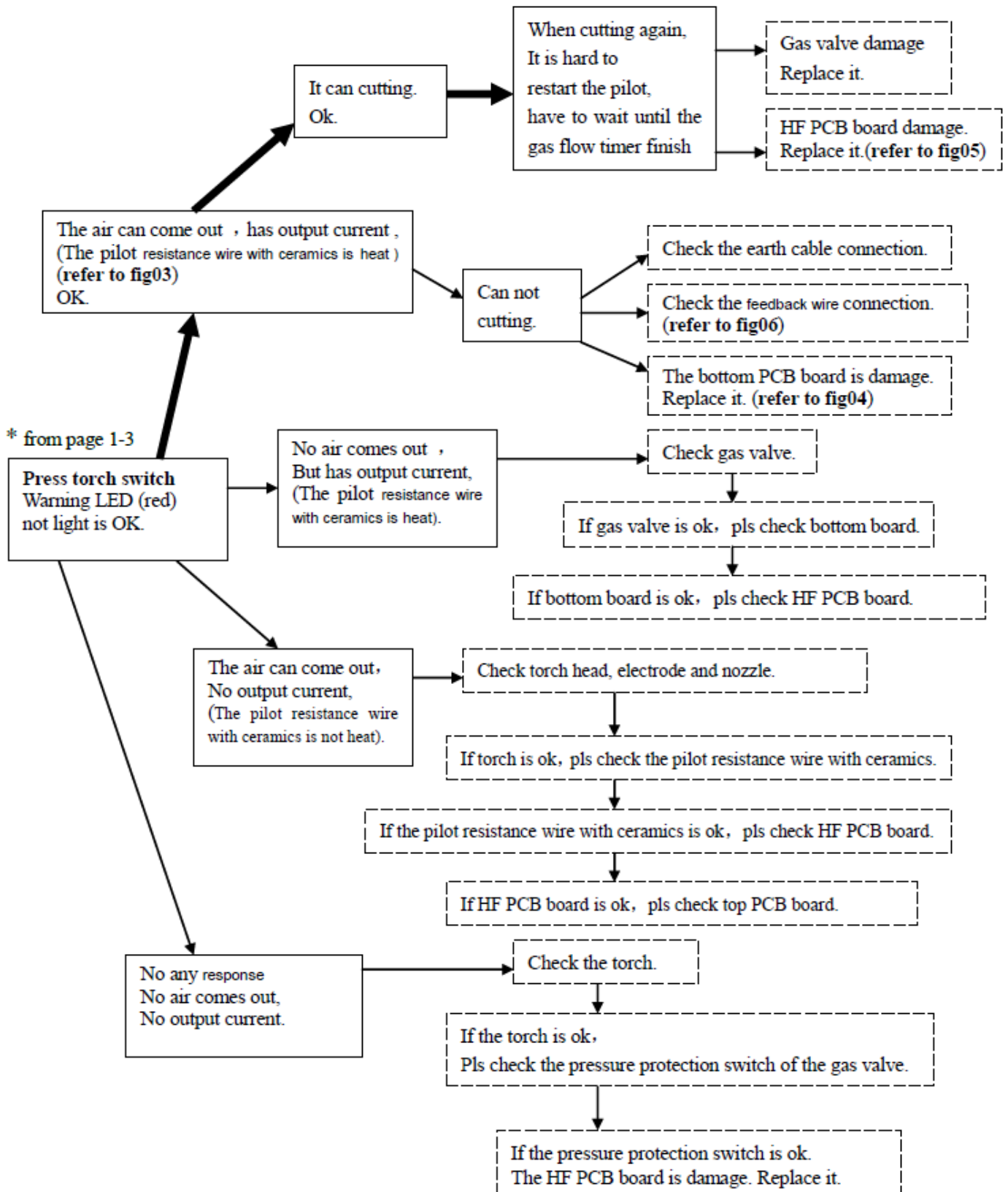

\* from page 1-3

**NOTE: When you open the machine cover to check the machine.  
Please check all the connectors are good connection, first.**

DC200-300V voltage

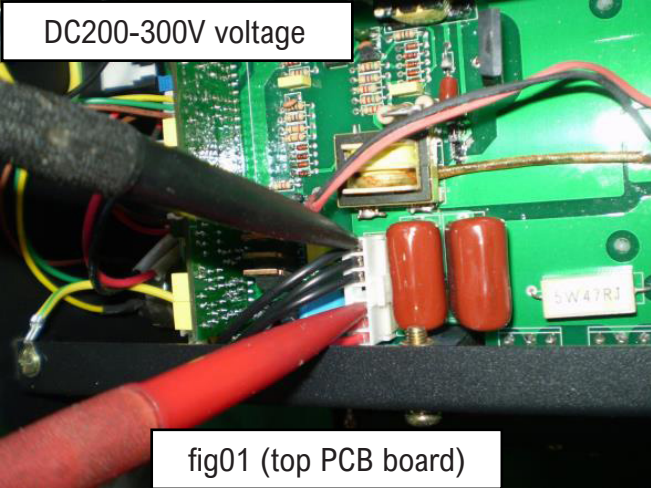

fig01 (top PCB board)

Remove the 7 pin plug

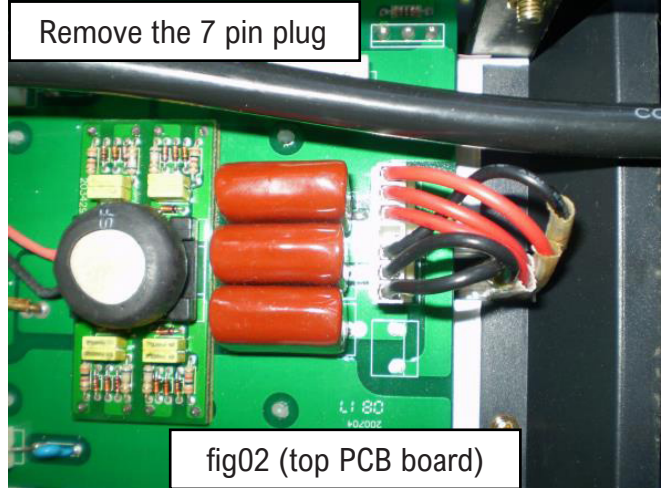

fig02 (top PCB board)



fig03 (resistance wire with ceramics)

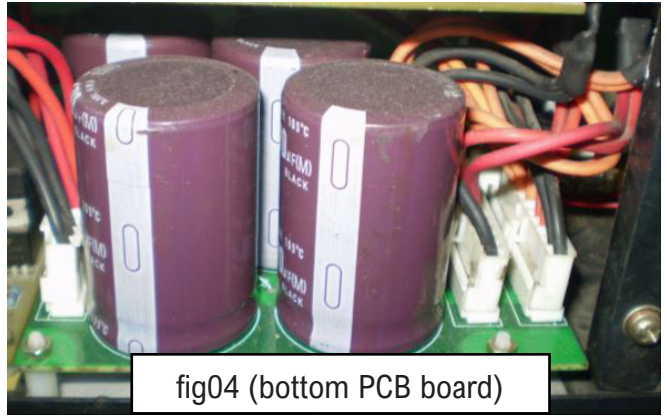

fig04 (bottom PCB board)

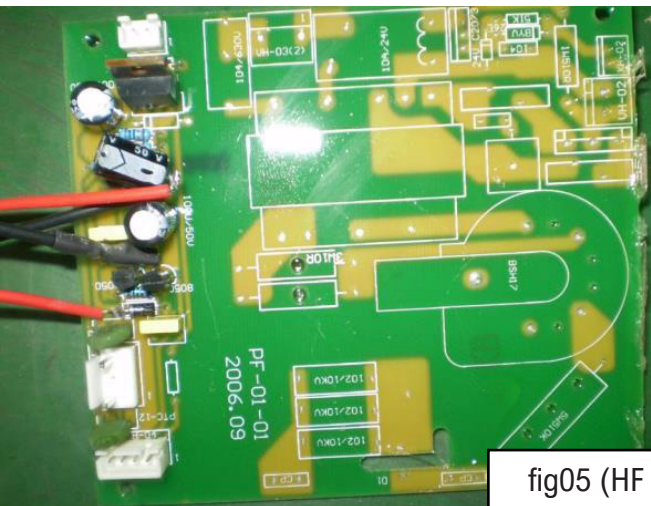

fig05 (HF PCB board)

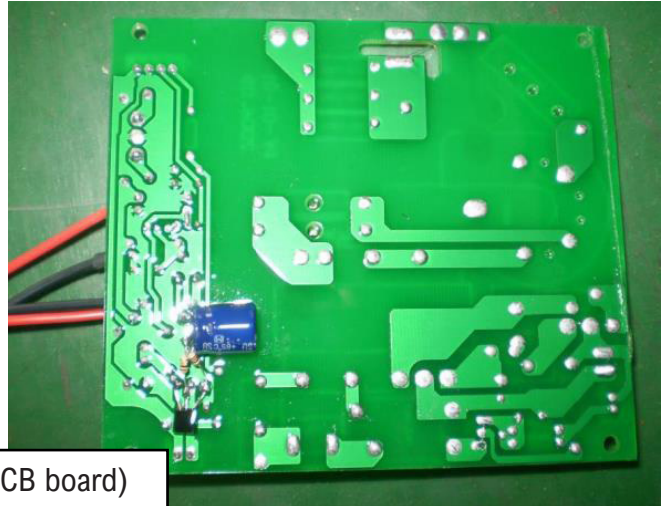

fig06 (feedback wire)

to mid PCB board

to earth cable connector

# 8. WIRE DRAWING:

## WIRE DRAWING FOR PLASMA CUT40 NH 20200418:

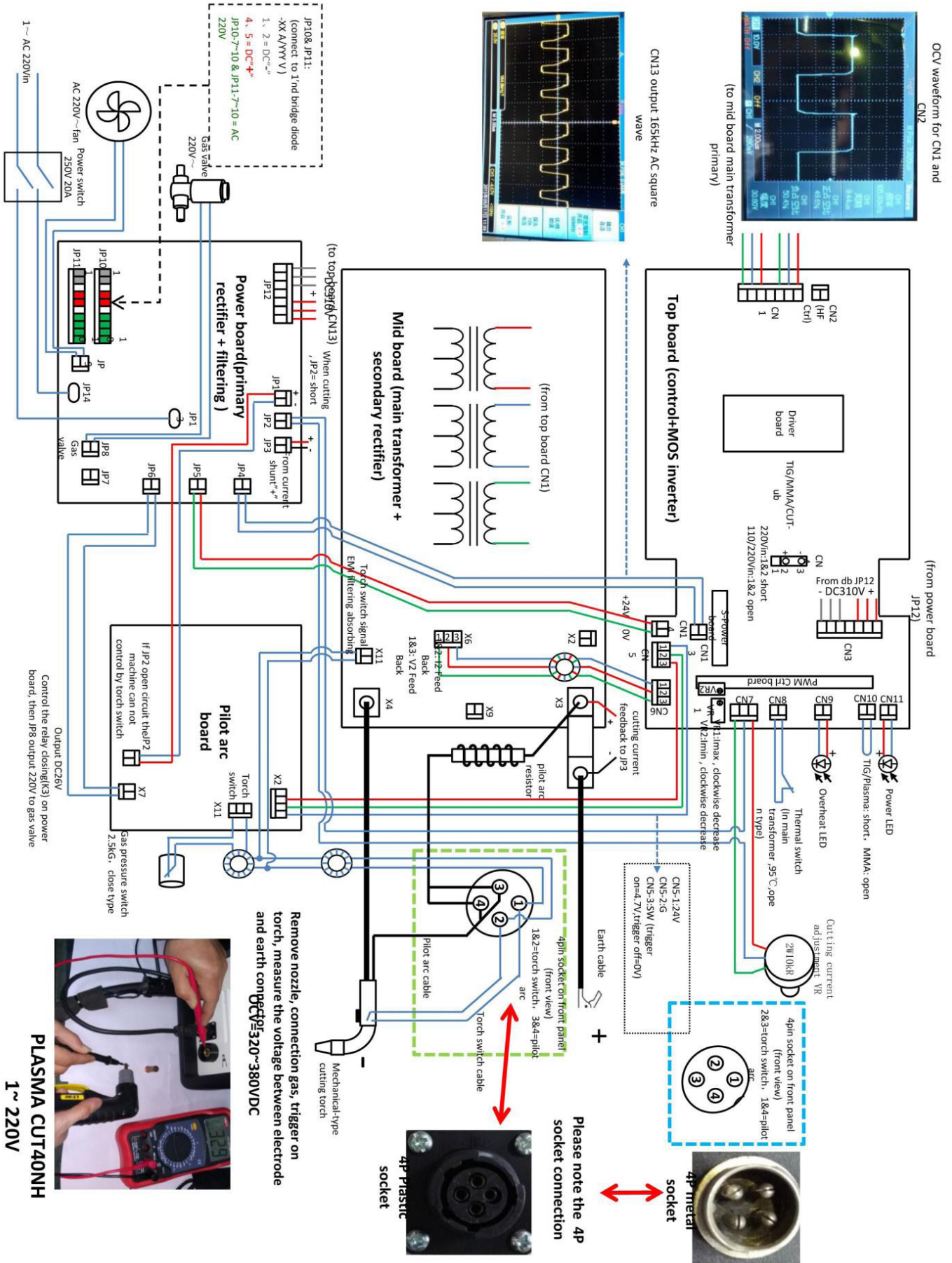

## 9. PLASMA CUT40NH 1PH/230V EUROPE/INDIA:

No.	Code	Description	No.	Code	Description
1	RA055009-1	Potentiometer 2W 10KΩ	15-1	MF055010	Fan net
	SE055001-B	Knob	16	ED073001	Radiator(right)
2	DL073002	Red LED	17	PB071300	CUT40 PCB(up)
	DL073003	Green LED	18	SC091120	Handle
3	KE082000	Power switch	19	ED073000	Radiator(left)
5	JC073008-1B	Socket for torch	20	RB081030	Resistance
6	JC055019-4	Socket for earth	21	EY1721-B2S0101R16	Top cover
7	JG071007	Control socket	22	PC073001-2	CUT40 PCB(mid)
8	PC072401	CUT40 Pilot arc PCB	23	EY1721-B2X0101B1	Bottom board
9	SG073014	Foot	24	EY1721-B2Q0101B1	Front panel
10	PC073001-2	CUT40 power and gas control PCB	25	BF055008-6A	Pressure regulating filter
11	DC073000	Rectifier	27	EY1721-B2H0101B1	Back panel
12	BF074012	Solenoid valve	28	JC055019-2	Plug for earth
13	XE073200-E	Power cord	29	XC055000-2E	Earth cable
14	BF055003-3D	Gas connector	30	JA064000	Earth clamp
15	MF073001-1	Fan			

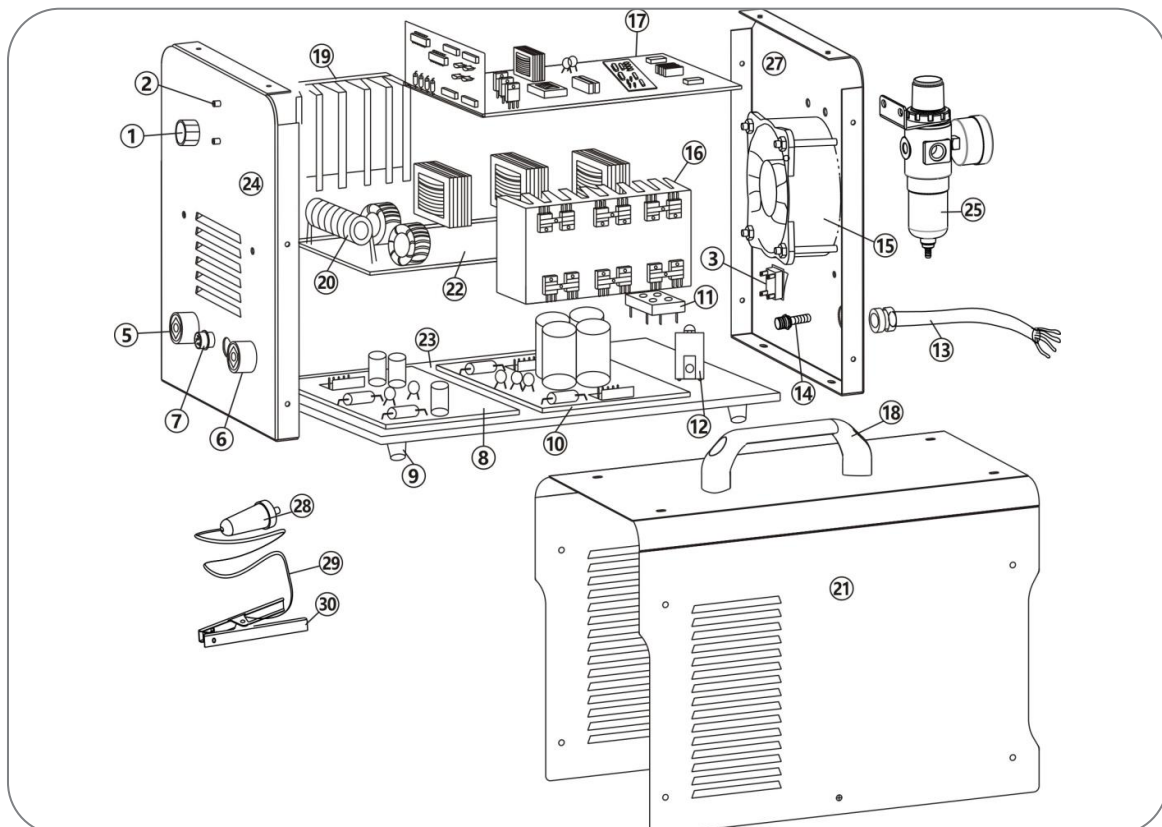



## 10. PLASMA CUT40NH 1PH/220V USA:

No.	Code	Description	No.	Code	Description
1	RA055009-1	Potentiometer 2W 10KΩ	15-1	MF055010	Fan net
	SE055001-B	Knob	16	ED073001	Radiator(right)
2	DL073002	Red LED	17	PB071300	CUT40 PCB(up)
	DL073003	Green LED	18	SC091120	Handle
3	KE082000	Power switch	19	ED073000	Radiator(left)
5	JC073008-1B	Socket for torch	20	RB081030	Resistance
6	JC055019-4	Socket for earth	21	EY1721-B2S0101R16	Top cover
7	JG071007	Control socket	22	PC073001-2	CUT40 PCB(mid)
8	PC072401	CUT40 Pilot arc PCB	23	EY1721-B2X0101B1	Bottom board
9	SG073014	Foot	24	EY1721-B2Q0101B1	Front panel
10	PC073001-2	CUT40 power and gas control PCB	25	BF055008-6A	Pressure regulating filter
11	DC073000	Rectifier	27	EY1721-B2H0101B1	Back panel
12	BF074012	Solenoid valve	28	JC055019-2	Plug for earth
13	XE072001	Power cord UL	29	XC055000-2E	Earth cable
14	BF055003-3D	Gas connector	30	JA064000	Earth clamp
15	MF073001-1	Fan			

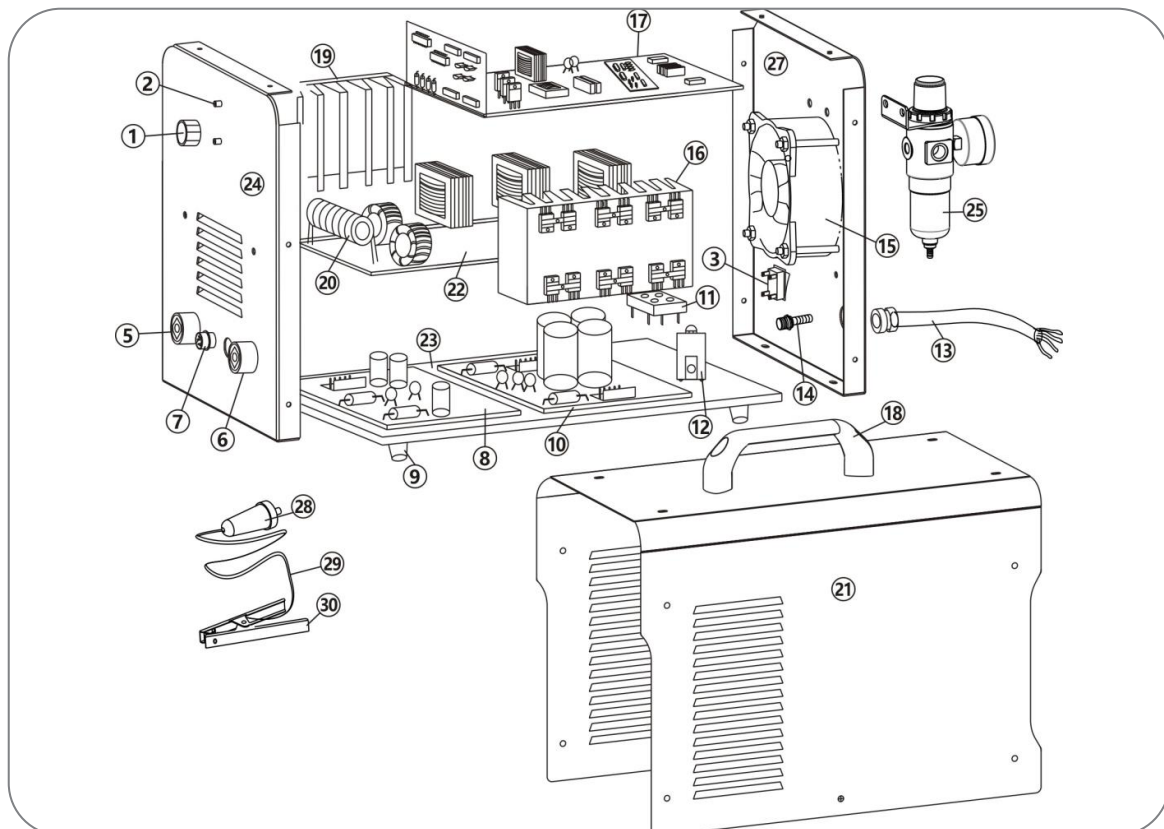

**THANK YOU!!!**  
**FOR PURCHASING OUR PRODUCT**



**CELETTE FRANCE SAS**

3, Avenue Marcellin Berthelot 38200 Vienne – France

+33 474 575 959

[info@celette.com](mailto:info@celette.com)

[www.celette.com](http://www.celette.com)

